

# AES256GCM10GIP Reference Design

Rev1.00 22-Jun-2022

## 1 Introduction

This document describes the detail of AES256GCM10GIP reference design. In this reference design, AES256GCM10GIP are used to encrypt and decrypt data between two memories in FPGA and provide authentication tag. User can fill memory with Additional Authenticated Data (AAD), plain or cipher data patterns, set encryption/decryption key, Initialization Vector (IV), and control test operation via serial console on test PC. More details of the hardware design and CPU firmware are described as follows.

## 2 Hardware Overview

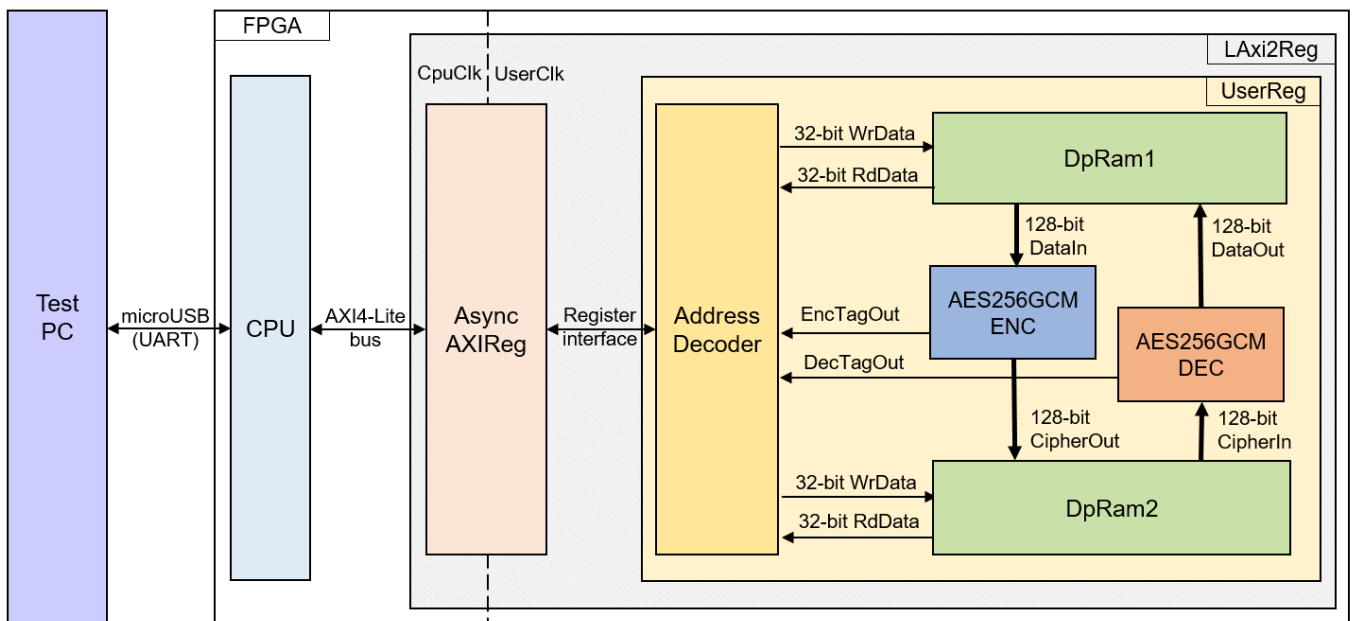

Figure 2-1 AES256GCM10GIP reference design block diagram

In this test environment, two AES256GCM10GIPs, called AES256GCMENC and AES256GCMDEC, interface with two dual-port RAMs with asymmetric ports, which are DpRam1 and DpRam2, as shown in Figure 2-1. AES256GCM10GIP and two RAMs are sub-modules in UserReg module within LAXi2Reg. CPU system is designed to interface with FPGA logic through AXI4 Lite bus and interface with user through serial console in test PC.

For user control interface, there are registers in UserReg to store parameters from user such as encryption/decryption key, IV, number of AAD and data to encrypt or decrypt. Input parameters are received from user via serial console.

For user data interface, UserReg is designed to be able to write pattern data or read data in RAMs following user's command and read encryption and decryption tag. DpRam1 is used to store encryption AAD and the plain data from user which will be input data for AES256GCMENC in encryption mode or the decrypted data which is output data from AES256GCMDEC in decryption mode. DpRam2 is used to store decryption AAD and the cipher data from user which will be input data for AES256GCMDEC in decryption mode or encrypted data which is output data from AES256GCMENC in encryption mode. Encryption/Decryption tag is stored in registers which user can read.

Because CPU system and AES256GCMENC/AES256GCMDEC run in different clock domain, AsyncAXIReg module inside LAXi2Reg is designed as asynchronous circuit to support clock-crossing operation. Also, AsyncAXIReg converts AXI4-Lite bus signal which is standard bus in CPU system to be register interface. The details of LAXi2Reg module are described below.

## 2.1 LAXi2Reg

LAXi2Reg module is connected to CPU through AXI4-Lite bus. The hardware registers are mapped to CPU memory address, as shown in Table 2-1. The control and status registers for CPU access are designed in LAXi2Reg.

LAXi2Reg consists of AsyncAxiReg and UserReg. AsyncAxiReg is designed to convert the AXI4-Lite signals to be the simple register interface which has 32-bit data bus size (similar to AXI4-Lite data bus size). Additionally, as shown in Figure 2-1, there are two clock domains applied in this block, i.e., CpuClk which is used to interface with CPU through AXI4-Lite bus and UserClk which is user clock domain for AES256GCMENC/AES256GCMDEC. AsyncAxiReg includes asynchronous circuit between CpuClk and UserClk.

UserReg includes the register file of the parameters and the status signals of test logics, including dual-port rams and AES256GCM10GIP. Both data interface and control interface of AES256GCM10GIP are connected to UserReg. More details of AsyncAxiReg and UserReg are described as follows.

## 2.2 AsyncAxiReg

This module is designed to convert the signal interface of AXI4-Lite to be register interface. Also, it enables two clock domains, CpuClk and UserClk domain, to communicate.

To write register, RegWrEn is asserted to '1' with the valid signal of RegAddr (Register address in 32-bit unit), RegWrData (write data of the register), and RegWrByteEn (the byte enable of this access: bit[0] is write enable for RegWrData[7:0], bit[1] is used for RegWrData[15:8], ..., and bit[3] is used for RegWrData[31:24]).

To read register, AsyncAxiReg asserts RegRdReq='1' with the valid value of RegAddr (the register address in 32-bit unit). After that, the module waits until RegRdValid is asserted to '1' to get the read data through RegRdData signal at the same clock.

## 2.3 UserReg

This module is designed to write/read data in RAMs, read tag, control and check status of AES256GCMENC and AES256GCMDEC corresponding with write register access or read register request from AsyncAxiReg module. Memory map inside UserReg module is shown in Table 2-1. Timing diagram of register interface is shown in Figure 2-2.

**Table 2-1 Register map Definition**

Address offset (From base address)	Register Name	Rd/Wr	Description
0x0000	ADDR_A1_REG	Rd/Wr	[6:0] – address A of DpRam1 (rAddrA1[10:4]).
0x0004	ADDR_A2_REG	Rd/Wr	[6:0] – address A of DpRam2 (rAddrA2[10:4]).
0x0008	ENC_AADCNT_REG	Wr	[15:0] – length of AAD for encryption (rEncAadInCount[15:0]).
0x000C	DEC_AADCNT_REG	Wr	[15:0] – length of AAD for decryption (rDecAadInCount[15:0]).
0x0010	ENC_DATAINCNT_REG	Rd	[0] – AES256GCMENC busy status (wEncBusy).
		Wr	[15:0] – length of plain data for encryption (rEncDataInCnt[15:0]). rEncStart is asserted to '1' and encryption process is started.
0x0014	DEC_DATAINCNT_REG	Rd	[0] – AES256GCMDEC busy status (wDecBusy).
		Wr	[15:0] – length of cipher data for decryption (rDecDataInCnt[15:0]). rDecStart is asserted to '1' and decryption process is started.
0x0018	ENC_VER_REG	Rd	[31:0] – AES256GCMENC IP version (wEncVersion).
0x001C	DEC_VER_REG	Rd	[31:0] – AES256GCMDEC IP version (wDecVersion).
0x0020	ENC_KEYIN_0_REG	Rd/Wr	[31:0] – Encryption key (rEncKeyIn[31:0]).
0x0024	ENC_KEYIN_1_REG	Rd/Wr	[31:0] – Encryption key (rEncKeyIn[63:32]).
0x0028	ENC_KEYIN_2_REG	Rd/Wr	[31:0] – Encryption key (rEncKeyIn[95:64]).

0x002C	ENC_KEYIN_3_REG	Rd/Wr	[31:0] – Encryption key (rEncKeyIn[127:96]).
0x0030	ENC_KEYIN_4_REG	Rd/Wr	[31:0] – Encryption key (rEncKeyIn[159:128]).
0x0034	ENC_KEYIN_5_REG	Rd/Wr	[31:0] – Encryption key (rEncKeyIn[191:160]).
0x0038	ENC_KEYIN_6_REG	Rd/Wr	[31:0] – Encryption key (rEncKeyIn[223:192]).
0x003C	ENC_KEYIN_7_REG	Rd/Wr	[31:0] – Encryption key (rEncKeyIn[255:224]).
0x0040	DEC_KEYIN_0_REG	Rd/Wr	[31:0] – Decryption key (rDecKeyIn[31:0]).
0x0044	DEC_KEYIN_1_REG	Rd/Wr	[31:0] – Decryption key (rDecKeyIn[63:32]).
0x0048	DEC_KEYIN_2_REG	Rd/Wr	[31:0] – Decryption key (rDecKeyIn[95:64]).
0x004C	DEC_KEYIN_3_REG	Rd/Wr	[31:0] – Decryption key (rDecKeyIn[127:96]).
0x0050	DEC_KEYIN_4_REG	Rd/Wr	[31:0] – Decryption key (rDecKeyIn[159:128]).
0x0054	DEC_KEYIN_5_REG	Rd/Wr	[31:0] – Decryption key (rDecKeyIn[191:160]).
0x0058	DEC_KEYIN_6_REG	Rd/Wr	[31:0] – Decryption key (rDecKeyIn[223:192]).
0x005C	DEC_KEYIN_7_REG	Rd/Wr	[31:0] – Decryption key (rEncKeyIn[255:224]).
0x0060	ENC_IVIN_0_REG	Rd/Wr	[31:0] – Encryption IV (rEnclvIn[31:0]).
0x0064	ENC_IVIN_1_REG	Rd/Wr	[31:0] - Encryption IV (rEnclvIn[63:32]).
0x0068	ENC_IVIN_2_REG	Rd/Wr	[31:0] - Encryption IV (rEnclvIn[95:64]).
0x0070	DEC_IVIN_0_REG	Rd/Wr	[31:0] - Decryption IV (rDeclvIn[31:0]).
0x0074	DEC_IVIN_1_REG	Rd/Wr	[31:0] - Decryption IV (rDeclvIn[63:32]).

0x0078	DEC_IVIN_2_REG	Rd/Wr	[31:0] - Decryption IV (rDecIvIn[95:64]).
0x0080	ENC_TAG_0_REG	Rd	[31:0] - Encryption tag (rEncTagOut[31:0]).
0x0084	ENC_TAG_1_REG	Rd	[31:0] - Encryption tag (rEncTagOut[63:32]).
0x0088	ENC_TAG_2_REG	Rd	[31:0] - Encryption tag (rEncTagOut[95:64]).
0x008C	ENC_TAG_3_REG	Rd	[31:0] - Encryption tag (rEncTagOut[127:96]).
0x0090	DEC_TAG_0_REG	Rd	[31:0] - Decryption tag (rDecTagOut[31:0]).
0x0094	DEC_TAG_1_REG	Rd	[31:0] - Decryption tag (rDecTagOut[63:32]).
0x0098	DEC_TAG_2_REG	Rd	[31:0] - Decryption tag (rDecTagOut[95:64]).
0x009C	DEC_TAG_3_REG	Rd	[31:0] - Decryption tag (rDecTagOut[127:96]).
0x2000~0x23FF	PLAIN_BASE_ADDR	Rd/Wr	[31:0] – Plain data in DpRam1 (wRdDataB1).
0x2400~0x27FF	ENC_AAD_BASE_ADDR	Rd/Wr	[31:0] – Encryption AAD in DpRam1 (wRdDataB1).
0x4000~0x43FF	CIPHER_BASE_ADDR	Rd/Wr	[31:0] – Cipher data in DpRam2 (wRdDataB2).
0x4400~0x47FF	DEC_AAD_BASE_ADDR	Rd/Wr	[31:0] – Decryption AAD in DpRam2 (wRdDataB2).

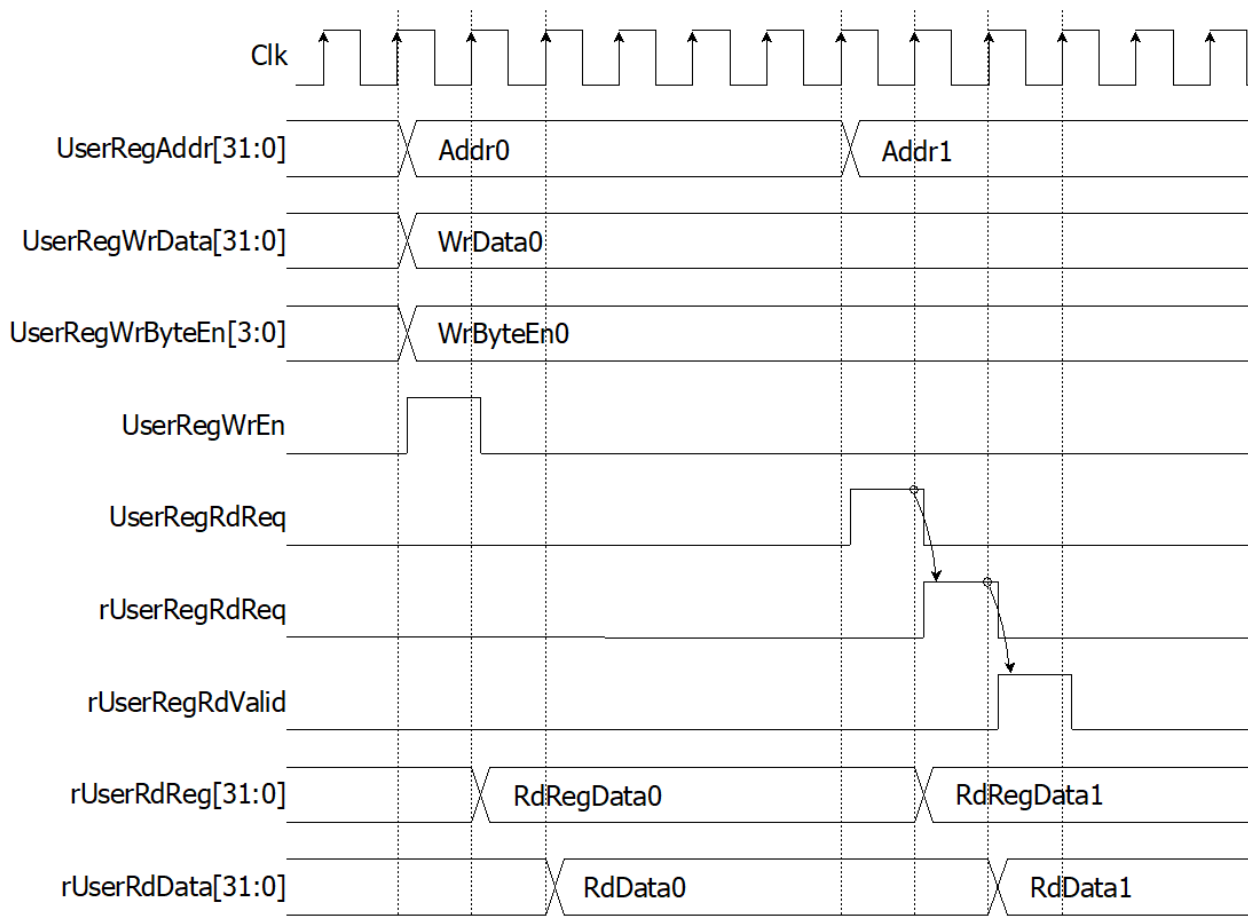

**Figure 2-2 Register interface timing diagram**

To read register, one multiplexer is designed to select the read data within each address area. UserRegAddr[10:2] is applied in each Register area to select the data. Next, the address decoder uses UserRegAddr[15:13] to select the read data from each area for returning to CPU. As shown in Figure 2-2, read data is valid in next two clock cycles. When UserRegRdReq is active, rUserRegRdReq is asserted to '1'. Then rUserRdValid is active with the valid read value of UserRegAddr.

To write register, UserRegWrEn is asserted to '1' with the valid of UserRegAddr. UserRegAddr[15:13] are used to decode that CPU accesses dual-port ram (DpRam) or internal register area. When CPU accesses DpRam (UserRegAddr[15:13]="001" or "010"), UserRegAddr[10:2] are set to be the address of DpRam. For example, when UserRegAddr[15:0]=0x2004 and UserRegWrEn='1', DpRam1 will be filled with UserRegWrData at Address 0x01. Otherwise, UserRegWrData is loaded to internal register which has matched UserRegAddr[10:0]. For example, rAddrA1 is loaded by UserRegWrData when UserRegAddr=0x0000.

UserRegWrByteEn signal is used when CPU firmware needs to access DpRam by using 64-bit, 32-bit, 16-bit or 8-bit pointer. UserRegWrByteEn[3:0] is mapped to Byte Write Enable port of DpRam.

In this reference design, there are three main operations which are parameter setting, encryption and decryption. Each operation is described as follows.

### 2.3.1 parameter setting

For encryption process, encryption key, encryption IV and length of encryption AAD are set by writing ENC\_KEYIN\_0\_REG to ENC\_KEYIN\_7\_REG, ENC\_IVIN\_0\_REG to ENC\_IVIN\_2\_REG and ENC\_AADCNT\_REG, respectively. AAD and plain data, which will be input data for AES256GCMENC, are stored in DpRam1. In case of non-zero length AAD, address A of DpRam1 (rAddrA1) is set to 0x40 to access the first AAD data by writing ADDR\_A1\_REG. Encrypted data from AES256GCMENC is stored in DpRam2. Before starting encryption process, address A of DpRam2 (rAddrA2) is set to 0x00 for writing the first output encrypted data by writing ADDR\_A2\_REG. For setting length of plain data, rEncDataInCnt, ENC\_DATAINCNT\_REG is written and then rEncStart is asserted to '1' to start encryption as shown in Figure 2-3.

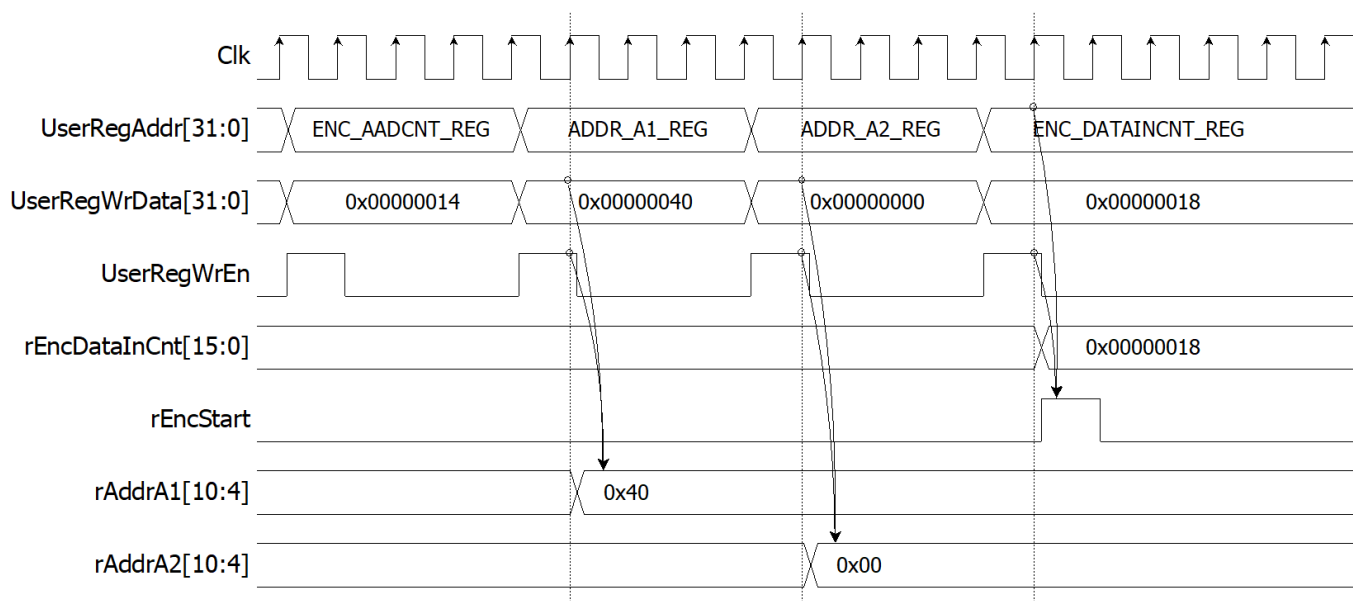

**Figure 2-3 Timing diagram example of encryption parameter setting**

For decryption process, decryption key, decryption IV and length of decryption AAD are set by writing DEC\_KEYIN\_0\_REG to DEC\_KEYIN\_7\_REG, DEC\_IVIN\_0\_REG to DEC\_IVIN\_2\_REG and DEC\_AADCNT\_REG respectively. AAD and cipher data, which will be input data for AES256GCMDEC, are stored in DpRam2. In case of non-zero length AAD, address A of DpRam2 (rAddrA2) is set to 0x40 to access the first AAD data by writing ADDR\_A2\_REG. Decrypted data from AES256GCMDEC is stored in DpRam1. Before starting decryption process, address A of DpRam1 (rAddrA1) is set to 0x00 for writing the first output decrypted data by writing ADDR\_A1\_REG. For setting length of cipher data, rDecDataInCount, DEC\_DATAINCNT\_REG is written and then rDecStart is asserted to '1' to start decryption as shown in Figure 2-4.

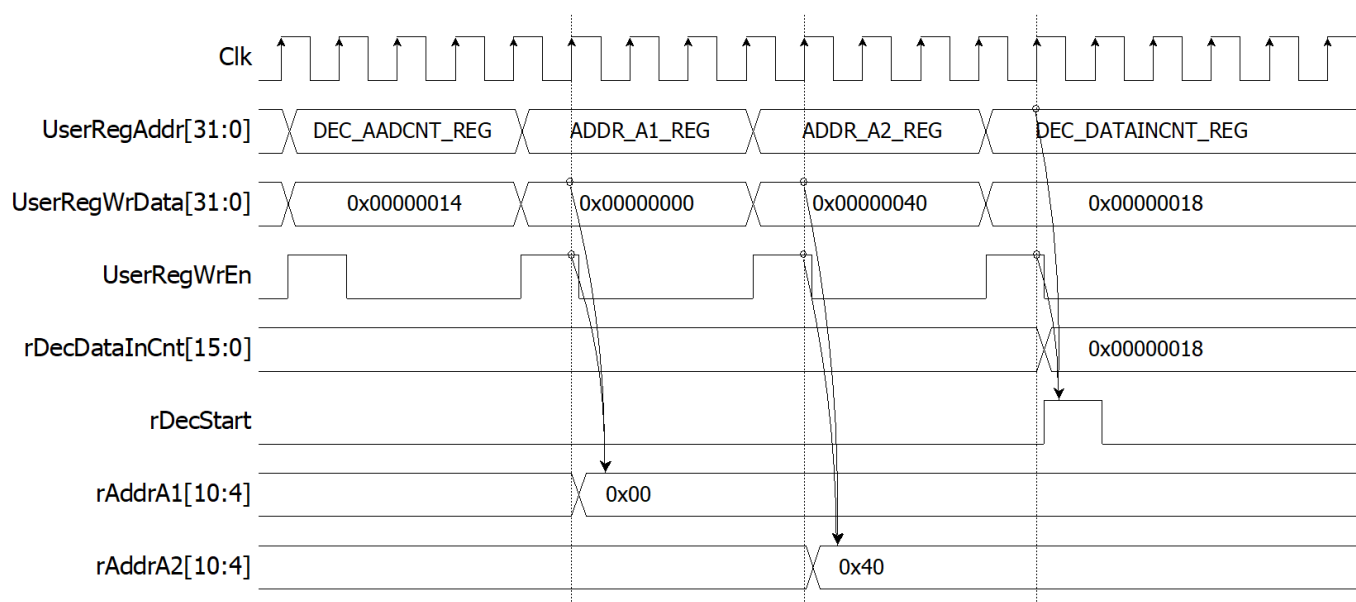

**Figure 2-4 Timing diagram example of decryption parameter setting**

### 2.3.2 Encryption

For encryption process, in case of non-zero length AAD, rAddrA1 is set to the first address of AAD and rEncAadCnt is set to be the number of 128-bit AAD. When wEncDataInRd is active, rAddrA1 is increased by 1 to access next 128-bit AAD and rEncAadCnt is decreased by 1 as the remaining 128-bit AAD to read. When rEncAadCnt=1 and wEncDataInRd='1', the last 128-bit AAD is read, rAddrA1 is reset to 0x00 to access the first plain data. When wEncDataInRd is active, rAddrA1 is increased by 1 to access next 128-bit plain data.

When wEncCipherOutValid is active, wEncCipherOut is loaded to DpRam2. Then rAddrA2 is increased by 1 prepared for next encrypted output as shown in Figure 2-5.

Encryption tag (wEncTagOut) is stored in register when wEncTagOutValid is active as shown in Table 2-1. User can access the encryption tag by reading ENC\_TAG\_0\_REG to ENC\_TAG\_7\_REG.



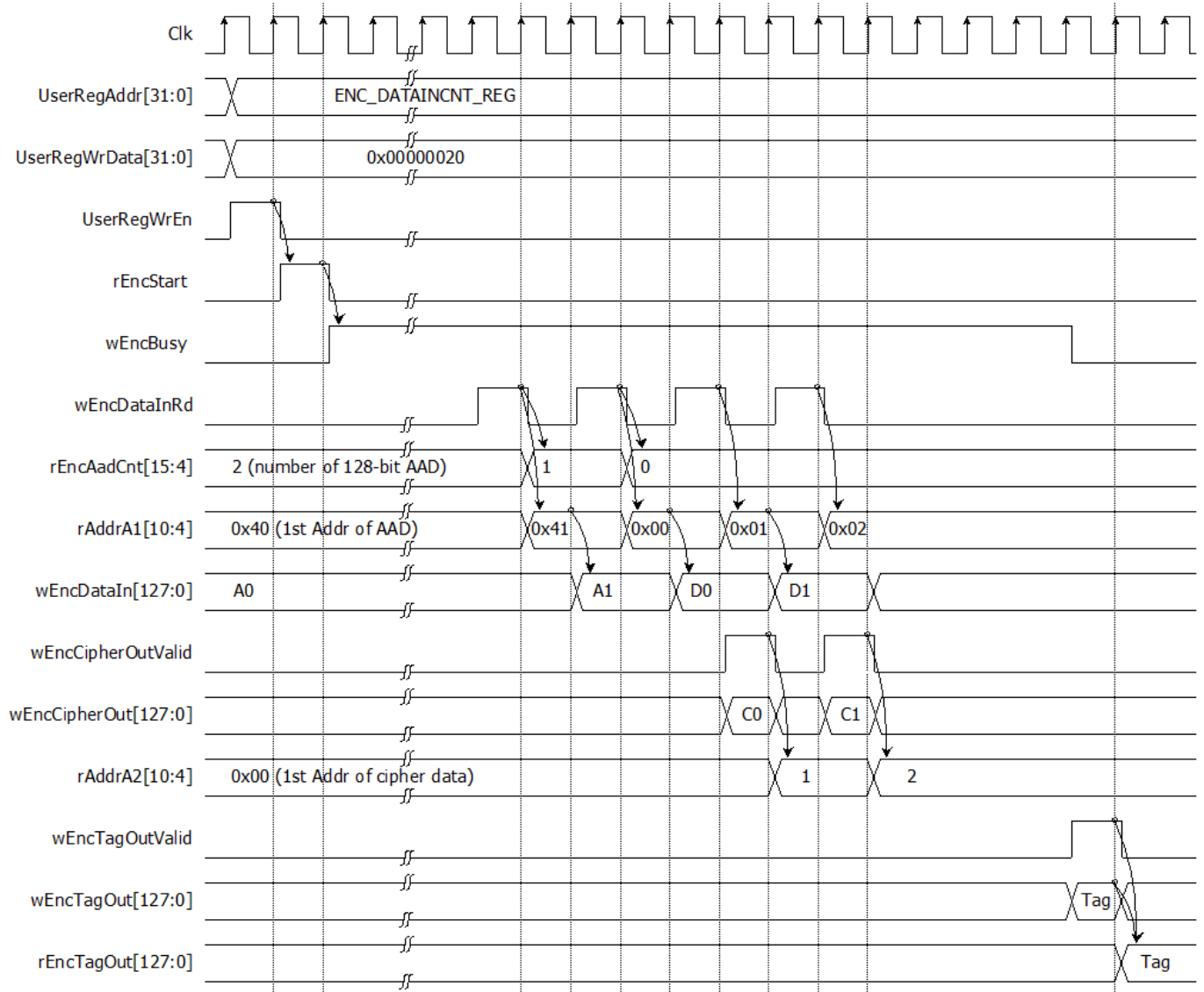

Figure 2-5 Timing diagram of encryption process

### 2.3.3 Decryption

For decryption process, in case of non-zero length AAD, rAddrA2 is set to the first address of AAD. and rDecAadCnt is set to be the number of 128-bit AAD. When wDecCipherInRd is active, rAddrA1 is increased by 1 to access next 128-bit AAD and rEncAadCnt is decreased by 1 as the remaining 128-bit AAD to read. When rDecAadCnt=1 and wDecCipherInRd='1', the last 128-bit AAD is read, rAddrA2 is reset to 0x00 to access the first cipher data. When wDecCipherInRd is active, rAddrA2 is increased by 1 to access next 128-bit cipher data.

When wDecDataOutValid is active, wDecDataOut is loaded to DpRam1. Then rAddrA1 is increased by 1 prepared for next decrypted output as shown in Figure 2-6.

Decryption tag (wDecTagOut) is stored in register when wDecTagOutValid is active as shown in Table 2-1. User can access the decryption tag by reading DEC\_TAG\_0\_REG to DEC\_TAG\_7\_REG.

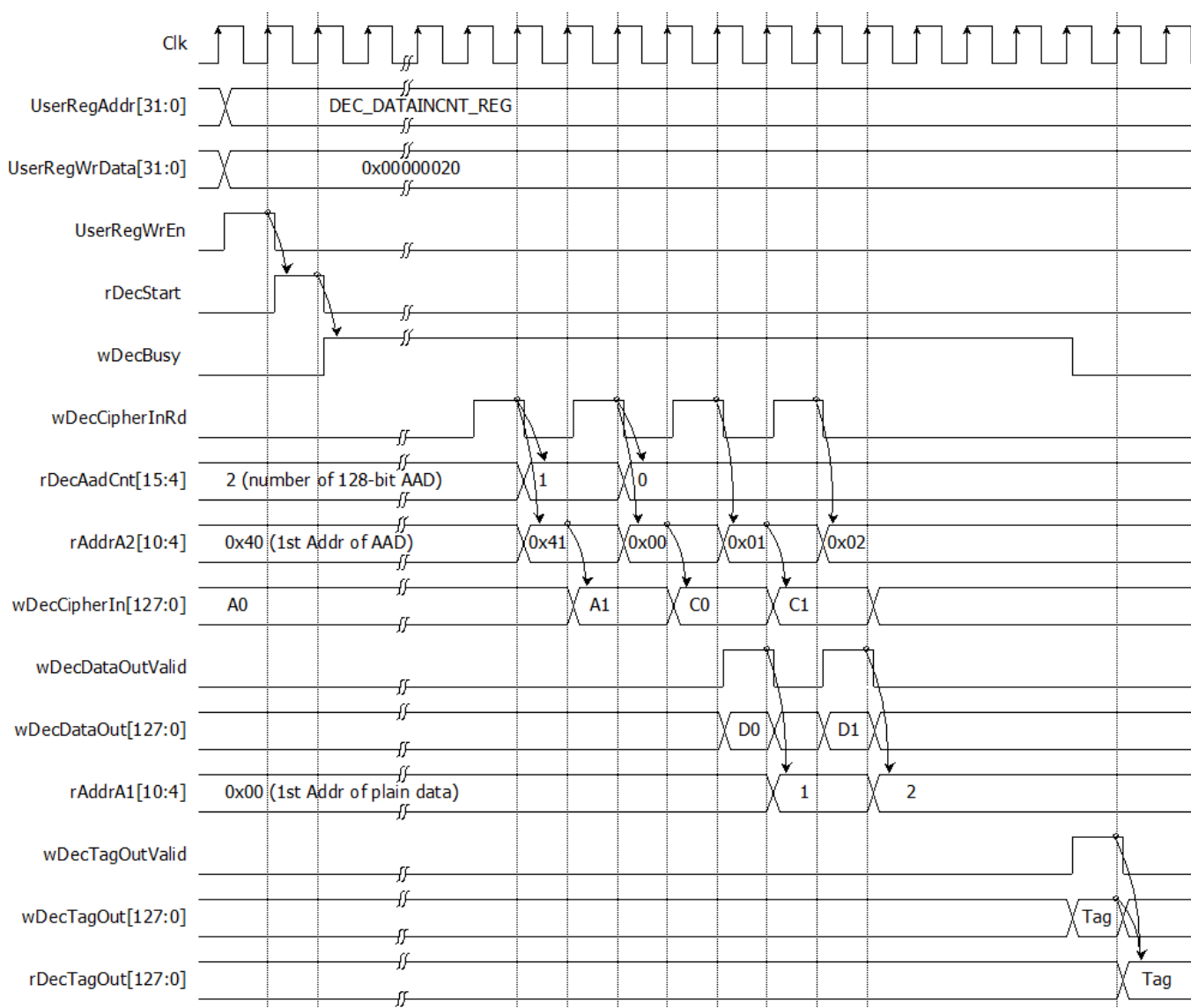

Figure 2-6 Timing diagram of decryption process

### 3 CPU Firmware

After system boot-up, CPU initializes its peripherals such as UART and Timer and shows IP version of AES256GCM10GIP. Then main menu is displayed. Main function runs in an infinite loop to show the main menu and get keyboard input from user. User can select each menu via serial console that will call the related functions. After functions finished running, the main menu is displayed again. More details of the sequence in each menu are described as follows.

#### 3.1 Set encryption/decryption key

This menu is used to set encryption/decryption key. The sequence of the firmware is as follows.

- 1) Call `change_key_set` function to change encryption/decryption key set. User can input “enter” key to skip input encryption key and not change current `enc_key_set` or to skip input decryption key and change `dec_key_set` similar to `enc_key_set`.
- 2) Call `set_enc_key` function and `set_dec_key` function inside `change_key_set` function to set `enc_key_set` and `dec_key_set` to mapped registers.

`change_key_set` function, `set_enc_key` function and `set_dec_key` function is described in Table 3-1, Table 3-2 and Table 3-3, respectively.

Table 3-1 change\_key\_set function

void change_key_set(unsigned int *enc_key_set, unsigned int *dec_key_set)	
Parameter	enc_key_set: pointer of array storing 256-bit encryption key dec_key_set: pointer of array storing 256-bit decryption key
Return value	None
Description	This function displays current encryption key on the console. Receive input new encryption key in hexadecimal format or “enter” key to skip. User’s input will be ignored if it is not hexadecimal format. The encryption/decryption key is stored in <code>enc_key_set/dec_key_set</code> . Then <code>set_enc_key</code> function and <code>set_dec_key</code> function is called, respectively.

Table 3-2 set\_enc\_key set function

void set_enc_key(unsigned int *enc_key_set)	
Parameter	enc_key_set: pointer of array storing 256-bit encryption key
Return value	None
Description	This function sets 256-bit encryption key to mapped registers. Before setting, AES256GCMENC status is monitored until the last operation is completed (*ENC_DATAINCNT_REG=0) then set the registers.

Table 3-3 set\_dec\_key set function

void set_dec_key(unsigned int *dec_key_set)	
Parameter	dec_key_set: pointer of array storing 256-bit decryption key
Return value	None
Description	This function sets 256-bit decryption key to mapped registers. Before setting, AES256GCMDEC status is monitored until the last operation is completed (*DEC_DATAINCNT_REG=0) then set the registers.

### 3.2 Set encryption/decryption IV

This menu is used to set encryption/decryption IV by calling set\_iv function. set\_iv function is described in Table 3-4.

Table 3-4 change\_key\_set function

void set_iv(unsigned int *enc_iv_set, unsigned int *dec_iv_set)	
Parameter	enc_iv_set: pointer of array storing 96-bit encryption IV dec_iv_set: pointer of array storing 96-bit decryption IV
Return value	None
Description	This function displays current encryption IV on the console. Receive input new encryption IV in hexadecimal format or “enter” key to skip. User’s input will be ignored if it is not hexadecimal format. The encryption/decryption IV is stored in enc_iv_set and dec_iv_set. Then the function monitors AES256GCMENC/AES256GCMDEC busy status until busy status is not active. Set enc_iv_set and dec_iv_set to rEnclvIn and rDeclvIn, respectively.

### 3.3 Set AAD for Encryption/Decryption

This menu is used to set the length of encryption/decryption AAD, fill DpRam1 with encryption AAD pattern and fill DpRam2 with decryption AAD pattern. The sequence of the firmware is as follows.

- 1) Receive the length of AAD in byte unit or “enter” key to set AAD length to zero. The length of AAD is stored in aad\_cnt which is used for both encryption and decryption.
- 2) Call fill\_data function to choose encryption AAD pattern and fill DpRam1 with selected pattern. The input parameters of fill\_data are ENC\_AAD\_BASE\_ADDR which is the first address for encryption AAD in DpRam1 and aad\_cnt. fill\_data function is described in Table 3-5.
- 3) Call show\_data function to show AAD data for both encryption AAD and decryption AAD corresponding to aad\_cnt. show\_data function is described in Table 3-6.
- 4) Call fill\_data function to choose decryption AAD pattern and fill DpRam2 with selected pattern. The input parameters of fill\_data is DEC\_AAD\_BASE\_ADDR which is the first address for decryption AAD in DpRam1 and aad\_cnt.
- 5) Call show\_data function to show AAD data for both encryption AAD and decryption AAD corresponding to aad\_cnt.

Table 3-5 fill\_data function

void fill_data(unsigned int base_addr, unsigned int data_length)	
Parameter	base_addr: base address to access memory data_length: length of data to fill data pattern
Return value	None
Description	This function fills the selected pattern in memory corresponding to base_addr. Before filling memory, the function shows data pattern choices on serial console and waits for user’s input. For invalid choice, the console will display the error message and wait until user input new valid choice. Then selected data pattern is filled into memory by the length of data (data length) and filled zeros into the remaining memory from address base_addr+0x0000 to base_addr+0x03FF.

### 3.4 Show Data Memory

This menu is used to show data in memory. AAD will be shown by the number of AAD that user already set. User can set the number of data to show on console in byte unit. The sequence of the firmware is as follows.

- 1) Call show\_data function to show AAD in memory with ENC\_AAD\_BASE\_ADDR and aad\_cnt as its parameters.
- 2) Receive the length of data in decimal format or “enter” key to use default value. If user input ‘0’, the length of data to show will be default value. The length of data to show is stored in length.
- 3) Call show\_data function to show data in memory with PLAIN\_BASE\_ADDR and length as its parameters.

Table 3-6 show\_data function

void show_data(unsigned int base_addr, unsigned int length)	
Parameter	base_addr: base address to access memory length: length of data to show
Return value	None
Description	This function shows data in both DpRam1 and DpRam2 corresponding to length. CPU firmware reads data in DpRam1, starting at base_addr, and shows on console. Also, CPU firmware reads data in DpRam2, starting at base_addr + 0x2000, and shows on console. If length is too large, length will be set to the size of memory.

### 3.5 Fill Plain Data Memory

This menu is used to fill DpRam1 with plain data pattern. The sequence of the firmware is as follows.

- 1) Receive the length of plain data in decimal format or “enter” key to set length of data to zero. The number of data to encrypt is stored in enc\_data\_cnt.
- 2) Call fill\_data function to choose data pattern and fill DpRam1 with selected pattern. The input parameter of fill\_data is PLAIN\_BASE\_ADDR which is base address for DpRam1 and enc\_data\_cnt.
- 3) Call show\_data function to show data in both DpRam1 and DpRam2 corresponding to enc\_data\_cnt.

According to Table 3-5, there are four data pattern choices to fill memory that are zero pattern, 8-bit counter pattern, 16-bit pattern and 32-bit pattern. For zero pattern, user can select this choice to clear data memory. It makes user see the output of encryption/decryption more clearly.

### 3.6 Encrypt

This menu is used to start encryption process with current encryption parameters. The sequence of the firmware is as follows.

- 1) Call aes\_command function to set mode of operation, the starting address, number of AAD and data to encrypt and check status. aes\_command function is described in Table 3-7.
- 2) Print AAD length and call show\_data function to show AAD in memory by the number of encryption AAD.
- 3) Print plain data length and call show\_data function to show data in memory by the number of plain data.
- 4) Call show\_tag function to display encryption tag. show\_tag function is described in Table 3-8.



**Table 3-7 aes\_command function**

<pre>void aes_command(unsigned char mode, unsigned int *AADCNT_REG, unsigned int aad_cnt, unsigned int *DATACNT_REG, unsigned int data_cnt)</pre>	
Parameter	<p>mode: mode of operation, 0 for encryption and 1 for decryption</p> <p>AADCNT_REG: register for AAD length</p> <p>aad_cnt: the number of AAD to operate</p> <p>DATACNT_REG: register for data length</p> <p>data_cnt: the number of data to operate</p>
Return value	None
Description	<p>This function sets the number of AAD by writing register AADCNT_REG with aad_cnt and sets the starting address of DpRam1 and DpRam2 by writing register ADDR_A1_REG and ADDR_A2_REG, respectively. Then DATACNT_REG is written with data_cnt to set the number of data to operate. Also, DATACNT_REG is monitored to check whether operation finish. When operation finished, *CMD_REG=0 which means AES256GCM10GIP is not busy (*DATACNT_REG[0]= '0').</p>

**Table 3-8 show\_tag function**

<pre>void show_tag(unsigned int *TAG_REG)</pre>	
Parameter	TAG_REG: register for reading authentication tag
Return value	None
Description	<p>This function reads authentication tag from TAG_REG to TAG_REG+0x000F and prints tag on serial console.</p>

### 3.7 Loop verification

This menu is used to verify both encryption and decryption with the current encryption and decryption parameters by calling loop\_verify function which is described in Table 3-9.

Table 3-9 loop\_verify function

int loop_verify(unsigned int aad_cnt, unsigned int data_cnt)	
Parameter	aad_cnt: the number of AAD for encryption and decryption data_cnt: the number of data for encryption and decryption
Return value	Int: 0 for verification succeeded and -1 for verification failed
Description	This function reads and stores plain data from DpRam1 for verification. Data in DpRam2 is cleared. aes_command function is called to encrypt plain data in DpRam1 with current encryption parameters. Then data in DpRam1 is cleared and aes_command function is called to decrypt data in DpRam2 with current decryption parameters. The decrypted data is compared with plain data before encryption process and decryption tag is compared with encryption tag. Verification result will be printed on serial console.

### 3.8 Fill Cipher Data Memory

This menu is used to fill DpRam2 with cipher data pattern. The sequence of the firmware is as follows.

- 1) Receive the length of cipher data in decimal format or “enter” key to set length of data to zero. The number of data to decrypt is stored in dec\_data\_cnt.
- 2) Call fill\_data function to choose data pattern and fill DpRam2 with selected pattern. The input parameter of fill\_data is CIPHER\_BASE\_ADDR which is base address for DpRam2 and dec\_data\_cnt.
- 3) Call show\_data function to show data in both DpRam1 and DpRam2 corresponding to dec\_data\_cnt.

### 3.9 Decrypt

This menu is used to start decryption process with current decryption parameters. The sequence of the firmware is as follows.

- 1) Call `aes_command` function to set mode of operation, the starting address, number of AAD and data to decrypt and check status.
- 2) Print AAD length and call `show_data` function to show AAD in memory by the number of decryption AAD.
- 3) Print cipher data length and call `show_data` function to show data in memory by the number of cipher data.
- 4) Call `show_tag` function to display decryption tag.

## 4 Revision History

Revision	Date	Description
1.00	22-Jun-2022	Initial version release