



Directly connect PCIe SSD without external memory!!



Evaluation on KCU105 with Samsung SSD 960 Pro

NVMe IP core interfaces Ultra high-speed PCIe SSD without CPU and external memory. It is the best solution for applications which require ultra high-speed performance with compact system. The IP core license includes the reference design for Xilinx FPGA boards to shorten development time and reduce the cost.

Free evaluation bit files for Xilinx FPGA boards are available. You can evaluate IP core performance before purchasing.

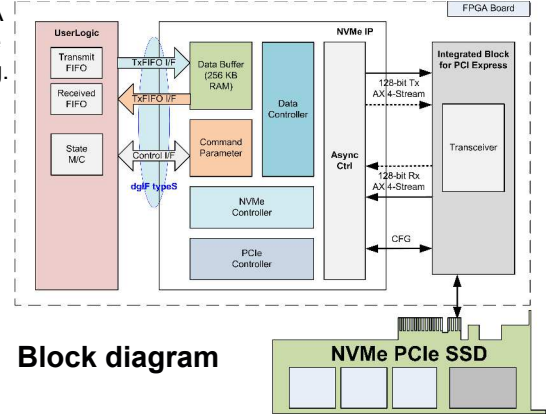

Features

- Implement application layer to access PCIe SSD without CPU and external memory
- Support PCIe Gen3, theoretical upper limit 4GB/sec
- Small resource, the best solution for building a compact system
- FAT32 access without CPU * with optional FAT32-IP
- Free evaluation before purchasing

Reference Designs are available for practical applications



2ch RAID



Linux driver

Easy to apply for high-end products such as ultra high-speed data recorder

Suitable for high-speed data recording and stand-alone data analysis on SoC

Performance / Application

Able to build Gen3 PCIe SSD 2ch RAID system!!

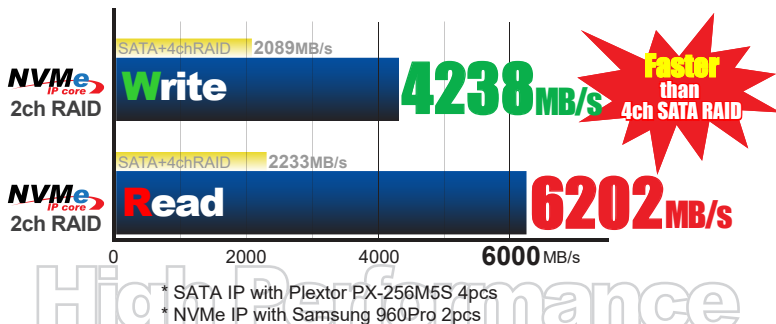

The best solution for Compact Ultra High-speed storage system!!

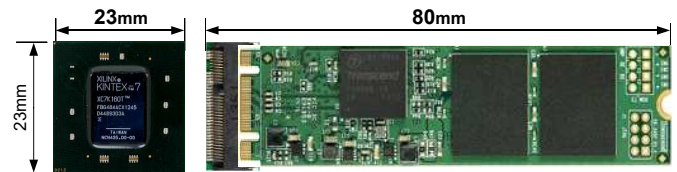

Kintex-7 (FBG484)
NVMe IP+ user logic

M.2 SSD
for data storage

System space image by 484pin FBG package FPGA with M.2 SSD

Product Line up

IP core	
NVMe-IP-KU	1 project Netlist License for Kintex UltraScale® PCIe Gen3
NVMe-IP-VT7	1 project Netlist License for Virtex®7 PCIe Gen3
NVMe-IP-KT7	1 project Netlist License for Kintex®7
NVMe-IP-AT7	1 project Netlist License for Artix®7
NVMe-IP-ZQ7	1 project Netlist License for Zynq®7000
NVMe-IP-FAT32-X	FAT32 file system for NVMe-IP. Purchase with NVMe-IP core

Please ask us about Multi-License, Evaluation License and Maintenance support License.

Accessories for evaluation

AB16-PCIeXOVER	PCIe Crossover Adapter board for NVMe IP evaluation
----------------	---

For more detail and technical information on our web site
http://www.dgway.com/NVMe-IP_X_E.html

YouTube search for "Designgateway IP core" and "IP core Evaluation Demo are available on youtube"

